

© 2023 MEISNER BREM CORPORATION
 THIS DOCUMENT AND THE WORK AND INFORMATION CONTAINED HEREIN, IS THE SOLE AND EXCLUSIVE PROPERTY OF MEISNER BREM CORPORATION, AND IS PROTECTED AS AN ORIGINAL WORK OF AUTHORSHIP UNDER THE COPYRIGHT ACT, AS SET FORTH IN TITLE 17 OF THE UNITED STATES CODE. ALL RIGHTS RESERVED. NEITHER THIS DOCUMENT, NOR ANY OF THE WORK OR INFORMATION CONTAINED HEREIN, MAY BE PRINTED, REPRODUCED, PUBLISHED, COPIED, SOLD, TRANSLATED, CONVERTED, ARRANGED, ADAPTED, DELIVERED OR PERFORMED, WITHOUT THE EXPRESS WRITTEN PERMISSION OF MEISNER BREM CORPORATION.

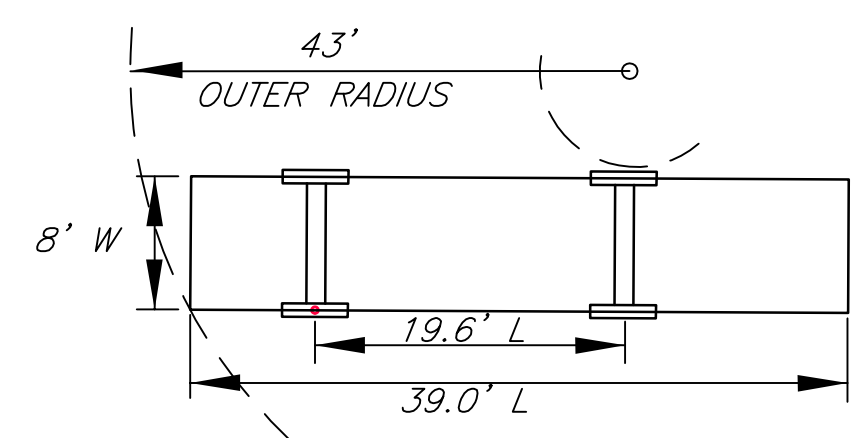

TURNING TEMPLATE EXHIBIT

REV 2	1-30-2024	UA
PRELIMINARY STORMWATER		
REV 1	1-3-2024	JAB/PDM
REDUCED TO 28 UNITS		

FIRE TURNING TEMPLATE
CHAPTER 40B - Residential Development
'Comprehensive Permit Plan Set'
Not For Construction
"Heritage Landing"
 Tax Map 248 Lot 42

COW POND BROOK ROAD
GROTON, MASSACHUSETTS
 PREPARED FOR:
 DEFCON 1 LLC
 390 Broadway Road
 Dracut, MA 01826
 APRIL 25, 2023

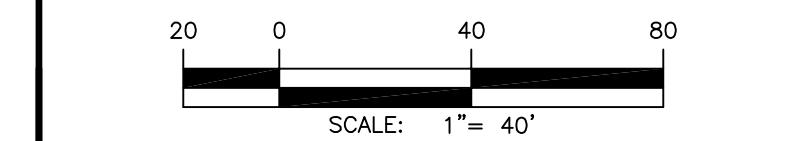

MEISNER BREM CORPORATION
 142 LITTLETON ROAD, STE. 16, WESTFORD, MA 01886 · (978) 692-1313
 202 MAIN STREET, SALEM, NH 03079 · (603) 893-3300

DRAFTED BY: UA/PDM
 APPROVED BY: JAB/KDM JOB NUMBER: 2944
 ACAD FILE: 2944-M.dwg **1 of 1**